

پیشگامان صنعت و ایمنی پرگاس

PISHGAMAN SANAAT & IMENI PERGAS



طراح، مشاور و مجری سیستم‌های ایمنی و تاسیساتی

دارای صلاحیت سازمان آتش‌نشانی تهران

اخذ تاییدیه آتش‌نشانی

برای اطلاعات بیشتر اسکن کنید



تهران . خیابان سعدی شمالی . خیابان

شهید هرادى نور . پلاک ۳۱ . واحد ۱



WWW.PERGAS-CO.IR



INFO@PERGAS-CO.IR



۷۷۶۸۶۹۶۶



۷۷۶۷۸۶۵۹



الکتروپمپ طبقاتی تمام استیل عمودی فشار قوی

مناسب جهت کاربردهای صنعتی و کشاورزی بطور مثال آتش نشانی، افزایش فشار آب آبیاری، انتقال آب سرد و گرم برای سیستم های حرارتی و تهویه مطبوع و مخصوص تغذیه دیگهای بخار به دلیل ساختار محکم پمپ و دستگاههای آب شیرین کن و RO

موتور	
2900	دور موتور (rpm)
F	کلاس عایق بندی
IP 55	درجه محافظت
توکار	خازن
50	فرکانس (Hz)
برای موتور تکفاز در نظر گرفته شده است.	
برای موتورهای سه فاز توسط مصرف کننده تامین می گردد.	
محافظ حرارتی اتوماتیک اضافه بار	محافظ حرارتی
جنس پوسته	آلومینیوم

EVM	32	2	-	2	F	5	/	30	M
نام مدل	دبی در نقطه بهترین راندمان (m³/h)	تعداد پروانه ها	تعداد پروانه های تراش خورده	فلنج دار (N-عینکی)	فرکانس ۵۰ هرتز	توان (kW)	فقط برای تکفاز		

پمپ	
آب تمیز ، آب (حاوی کلکول و مایعات خورنده ملایم)	نوع مایع
آب آشامیدنی	مشخصات سیال
+120	دما (°C)
-15	حداکثر فشار (Bar)
16-25-30	حداکثر ذرات معلق (ppm)
(اندازه ذرات 0.1 - 0.25 mm یا کمتر) 50	پروانه
سانتریفوژ بسته	نوع آبندی
مکانیکال سیل	یاتاقان
بلبرینگ دورو بسته با گریس دائمی	مکش/ارانش
خطی	اتصالات لوله
F (دایره ای) 25 N (بیضی) 16	حداکثر فشار مجاز فلنج (Bar)
استیل 304 برای مدل های EVM	پوسته پایین
استیل 316 برای مدل های EVML	پوسته میانی
چدن برای مدل های EVMG	پوسته بالایی
استیل 304 برای مدل های EVM , EVMG	پوسته خارجی
استیل 316 برای مدل های EVML	پروانه
استیل 304 برای مدل های EVM , EVMG	شفت
استیل 316 برای مدل های EVML	واسطه
استیل 304 برای مدل های EVM , EVMG	لاینرینگ (برای مدل های بالاتر از 32)
استیل 316 برای مدل های EVML	سیل مکانیکی
استیل 304 / EPDM برای EVM , EVMG استیل 316 / PTFE برای EVML	
Silicon Carbide/Carbon/FPM	

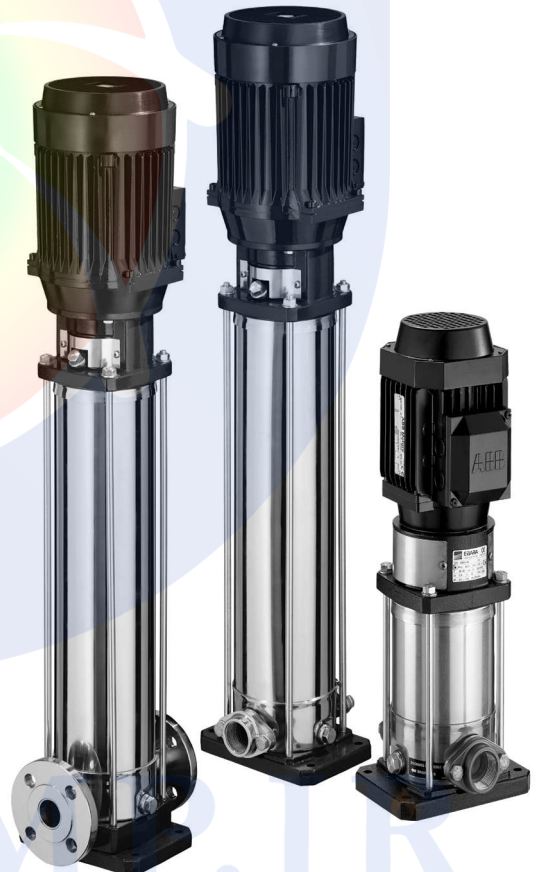



Vertical Multistage Pumps in AISI 304 , 316

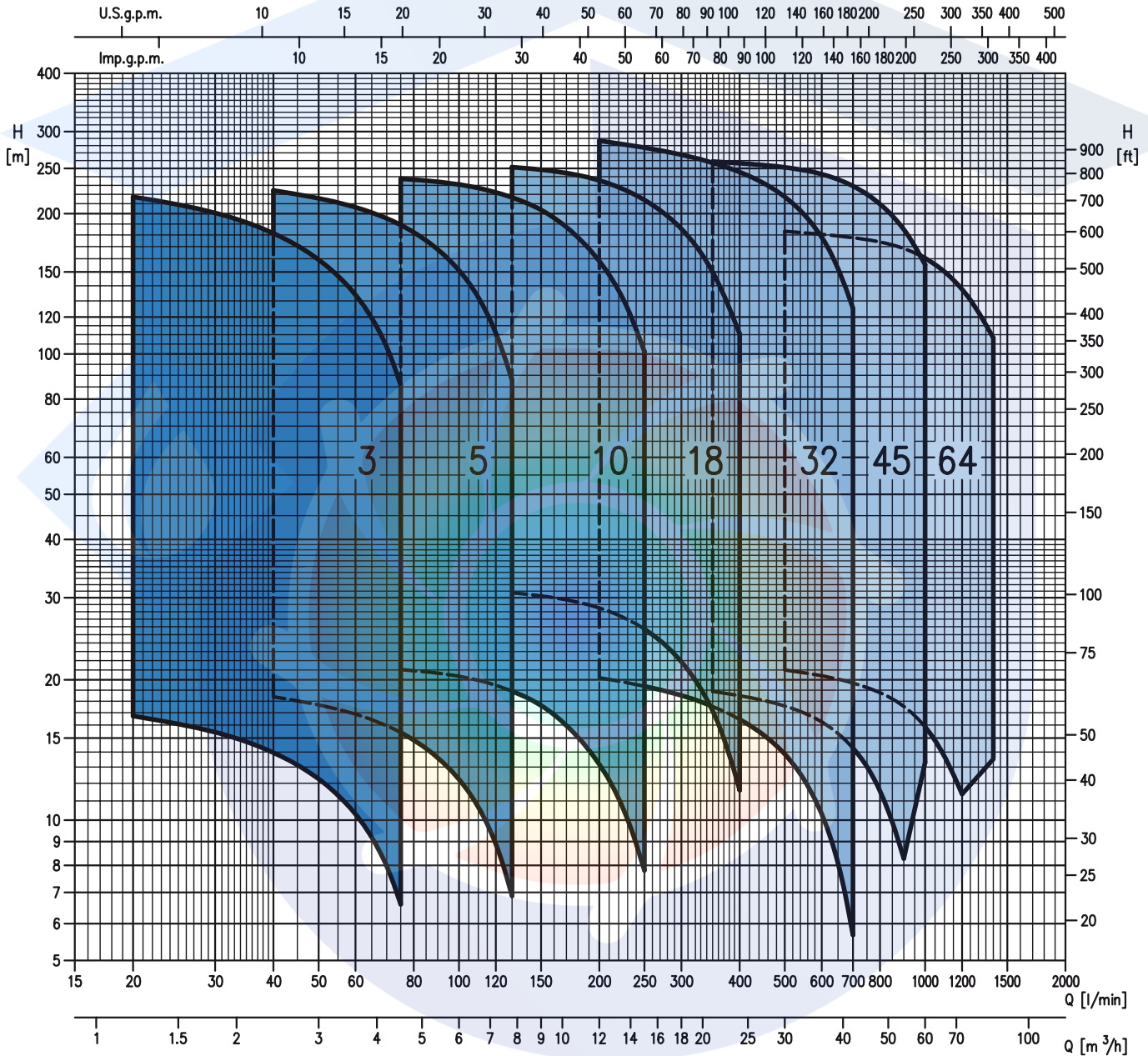

EDUPUMP.IR

EVM 3-18

Vertical Multistage Pumps in AISI 304 , 316

PERFORMANCE TABLE

جدول فنی

Pump Type EVM(.)	Motor kW HP Size	Maximum working pressure (MPa)	Q=Capacity														current [A]	
			l/min	20	40	60	75	100	130	150	200	250	300	350	400	Single Phase 230 V	Three Phase 400 V	
Single phase	Three phase		m³/h	1.2	2.4	3.6	4.5	6.0	7.8	9	12	15	18	21	24			
			H=Total manometric head in meters															
3 2N5/0.37 M	3 2N5/0.37	0.37	0.5	71	18.6	16.7	14.0	10.3	6.6	-	-	-	-	-	-	-	2.6	1.1
3 3N5/0.37 M	3 3N5/0.37	0.37	0.5	71	27.9	25.1	20.9	15.5	9.9	-	-	-	-	-	-	-	2.6	1.1
3 4N5/0.55 M	3 4N5/0.55	0.55	0.75	71	37.2	33.4	27.9	20.6	13.2	-	-	-	-	-	-	-	3.8	1.6
3 5N5/0.55 M	3 5N5/0.55	0.55	0.75	71	46.5	42.0	34.9	25.8	16.5	-	-	-	-	-	-	-	3.8	1.6
3 6N5/0.75 M	3 6N5/0.75	0.75	1	80	56.0	50.0	42.0	30.9	19.8	-	-	-	-	-	-	-	5.3	1.9
3 7N5/0.75 M	3 7N5/0.75	0.75	1	80	65.0	58.5	49.0	36.1	23.1	-	-	-	-	-	-	-	5.3	1.9
3 9N5/1.1 M	3 9N5/1.1	1.1	1.5	80	84.0	75.0	63.0	46.5	29.7	-	-	-	-	-	-	-	6.7	2.5
3 11N5/1.1 M	3 11N5/1.1	1.1	1.5	80	102.0	92.0	77.0	56.5	36.3	-	-	-	-	-	-	-	6.7	2.5
3 13N5/1.5 M	3 13N5/1.5	1.5	2	90S	121.0	109.0	90.5	67.0	43.0	-	-	-	-	-	-	-	8.8	3.4
3 15N5/1.5 M	3 15N5/1.5	1.5	2	90S	140.0	125.0	105.0	77.5	49.5	-	-	-	-	-	-	-	8.8	3.4
3 18F5/2.2 M	3 18F5/2.2	2.2	3	90L	167.0	151.0	126.0	92.5	59.5	-	-	-	-	-	-	-	12.9	4.9
3 22F5/2.2 M	3 22F5/2.2	2.2	3	90L	205.0	184.0	154.0	113.0	72.5	-	-	-	-	-	-	-	12.9	4.9
-	3 26F5/3.0	3	4	100	242.0	217.0	182.0	134.0	86.0	-	-	-	-	-	-	-	-	6.5
5 2N5/0.37 M	5 2N5/0.37	0.37	0.5	71	20.2	-	18.4	16.9	15.4	12.2	6.9	-	-	-	-	-	2.6	1.1
5 3N5/0.55 M	5 3N5/0.55	0.55	0.75	71	30.2	-	27.6	25.3	23.1	18.4	10.3	-	-	-	-	-	3.8	1.6
5 4N5/0.75 M	5 4N5/0.75	0.75	1	80	40.5	-	36.8	33.8	30.8	24.5	13.8	-	-	-	-	-	5.3	1.9
5 5N5/1.1 M	5 5N5/1.1	1.1	1.5	80	50.5	-	46.0	42.0	38.6	30.6	17.2	-	-	-	-	-	6.7	2.5
5 6N5/1.1 M	5 6N5/1.1	1.1	1.5	80	60.5	-	55.0	50.5	46.5	36.7	20.6	-	-	-	-	-	6.7	2.5
5 7N5/1.5 M	5 7N5/1.5	1.5	2	90S	70.5	-	64.5	59.0	54.0	43.0	24.1	-	-	-	-	-	8.8	3.4
5 8N5/1.5 M	5 8N5/1.5	1.5	2	90S	80.5	-	73.5	67.5	61.5	49.0	27.5	-	-	-	-	-	8.8	3.4
5 10N5/2.2 M	5 10N5/2.2	2.2	3	90L	102.0	-	93.5	86.0	79.0	63.0	36.6	-	-	-	-	-	12.9	4.9
5 11N5/2.2 M	5 11N5/2.2	2.2	3	90L	113.0	-	103.0	94.5	86.5	69.5	40.5	-	-	-	-	-	12.9	4.9
5 12N5/2.2 M	5 12N5/2.2	2.2	3	90L	123.0	-	112.0	103.0	94.5	75.5	44.0	-	-	-	-	-	12.9	4.9
-	5 14N5/3.0	3	4	100	143.0	-	131.0	120.0	110.0	88.0	51.0	-	-	-	-	-	-	6.5
-	5 16N5/3.0	3	4	100	164.0	-	150.0	138.0	126.0	101.0	58.5	-	-	-	-	-	-	6.5
-	5 18F5/4.0	4	5.5	112	184.0	-	168.0	155.0	142.0	113.0	66.0	-	-	-	-	-	-	8.5
-	5 19F5/4.0	4	5.5	112	194.0	-	178.0	163.0	150.0	120.0	69.5	-	-	-	-	-	-	8.5
-	5 22F5/4.0	4	5.5	112	225.0	-	206.0	189.0	173.0	139.0	80.5	-	-	-	-	-	-	8.5
-	5 24F5/5.5	5.5	7.5	132S	246.0	-	224.0	206.0	189.0	151.0	88.0	-	-	-	-	-	-	10.8
10 2N5/0.75 M	10 2N5/0.75	0.75	1	80	22.0	-	-	-	21.0	20.4	18.9	17.6	13.2	7.8	-	-	5.3	1.9
10 3N5/1.1 M	10 3N5/1.1	1.1	1.5	80	33.0	-	-	-	31.6	30.5	28.4	26.4	19.8	11.7	-	-	6.7	2.5
10 4N5/1.5 M	10 4N5/1.5	1.5	2	90S	44.0	-	-	-	42.0	40.5	37.8	35.2	26.4	15.6	-	-	8.8	3.4
10 5N5/2.2 M	10 5N5/2.2	2.2	3	90L	55.0	-	-	-	52.5	51.0	47.5	44.0	33.0	19.5	-	-	12.9	4.9
10 6N5/2.2 M	10 6N5/2.2	2.2	3	90L	66.0	-	-	-	63.0	61.0	57.0	53.0	39.5	23.4	-	-	12.9	4.9
-	10 8N5/3.0	3	4	100	88.0	-	-	-	84.0	81.5	75.5	70.5	52.5	31.2	-	-	-	6.5
-	10 10N5/4.0	4	5.5	112	110.0	-	-	-	105.0	102.0	94.5	88.0	66.0	39.0	-	-	-	8.5
-	10 11N5/4.0	4	5.5	112	121.0	-	-	-	116.0	112.0	104.0	97.0	72.5	43.0	-	-	-	8.5
-	10 12N5/5.5	5.5	7.5	132S	134.0	-	-	-	130.0	126.0	118.0	111.0	86.5	55.0	-	-	-	10.8
-	10 14N5/5.5	5.5	7.5	132S	157.0	-	-	-	151.0	147.0	138.0	130.0	101.0	64.5	-	-	-	10.8
-	10 15F5/5.5	5.5	7.5	132S	168.0	-	-	-	162.0	158.0	148.0	139.0	108.0	69.0	-	-	-	10.8
-	10 16F5/7.5	7.5	10	132S	179.0	-	-	-	173.0	168.0	158.0	148.0	115.0	73.5	-	-	-	14.1
-	10 18F5/7.5	7.5	10	132S	202.0	-	-	-	194.0	189.0	177.0	167.0	129.0	83.0	-	-	-	14.1
-	10 20F5/7.5	7.5	10	132S	224.0	-	-	-	216.0	210.0	197.0	185.0	144.0	92.0	-	-	-	14.1
-	10 22F5/11	11	15	160M	246.0	-	-	-	238.0	231.0	217.0	204.0	158.0	101.0	-	-	-	21.5
18 2F5/2.2 M	18 2F5/2.2	2.2	3	90L	32.0	-	-	-	-	31.0	30.3	28.5	25.7	21.9	17.2	11.6	12.9	4.9
-	18 3F5/3.0	3	4	100	48.0	-	-	-	-	46.0	45.5	43.0	38.6	32.8	25.7	17.4	-	6.5
-	18 4F5/4.0	4	5.5	112	64.0	-	-	-	-	61.5	60.5	57.0	51.5	44.0	34.3	23.2	-	8.5
-	18 5F5/5.5	5.5	7.5	132S	80.0	-	-	-	-	77.0	75.5	71.5	64.5	54.5	43.0	29.0	-	10.8
-	18 6F5/5.5	5.5	7.5	132S	96.0	-	-	-	-	92.0	91.0	85.5	77.0	65.5	51.5	34.8	-	10.8
-	18 7F5/7.5	7.5	10	132S	112.0	-	-	-	-	108.0	106.0	100.0	90.0	76.5	60.0	40.5	-	14.1
-	18 8F5/7.5	7.5	10	132S	128.0	-	-	-	-	123.0	121.0	114.0	103.0	87.5	68.5	46.5	-	14.1
-	18 10F5/11	11	15	160M	162.0	-	-	-	-	157.0	155.0	147.0	134.0	116.0	93.5	69.0	-	21.5
-	18 12F5/11	11	15	160M	194.0	-	-	-	-	189.0	186.0	177.0	160.0	139.0	112.0	83.0	-	21.5
-	18 14F5/15	15	20	160M	227.0	-	-	-	-	220.0	217.0	206.0	187.0	162.0	131.0	96.5	-	28.5
-	18 15F5/15	15	20	160M	243.0	-	-	-	-	236.0	233.0	221.0	201.0	174.0	141.0	104.0	-	28.5
-	18 16F5/15	15	20	160M	259.0	-	-	-	-	252.0	249.0	236.0	214.0	186.0	150.0	110.0	-	28.5

1.6 MPa=16 bar
2.5 MPa=25 bar

EVM 10,18

Vertical Multistage Pumps in AISI 304, 316

EVM 10

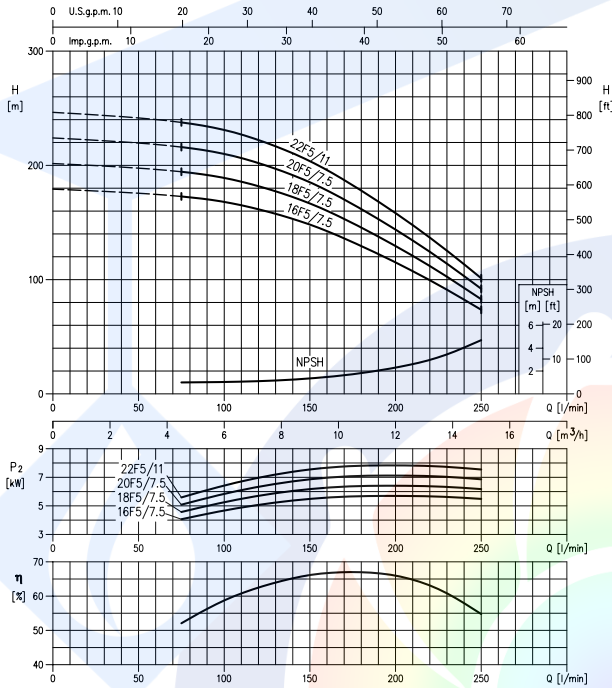

Rotation speed $\approx 2850 \text{ min}^{-1}$
Test standard: ISO 9906-Annex A

EVM 18

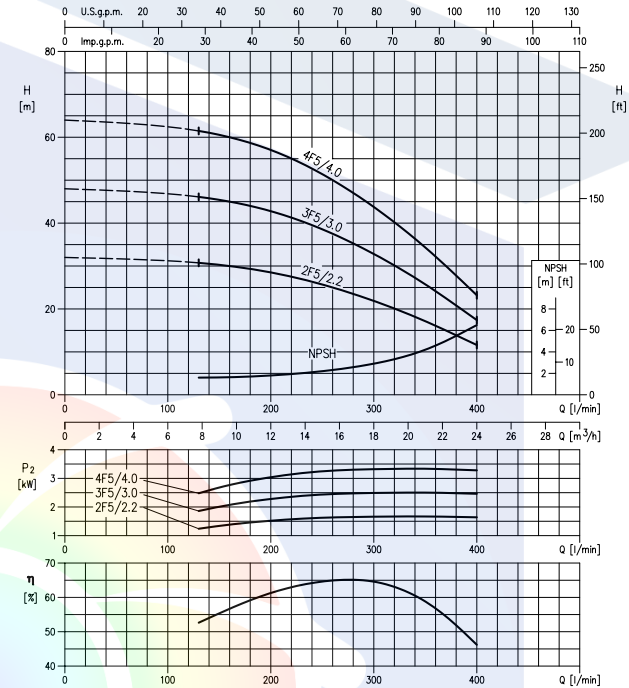

Rotation speed $\approx 2850 \text{ min}^{-1}$
Test standard: ISO 9906-Annex A

EVM 18

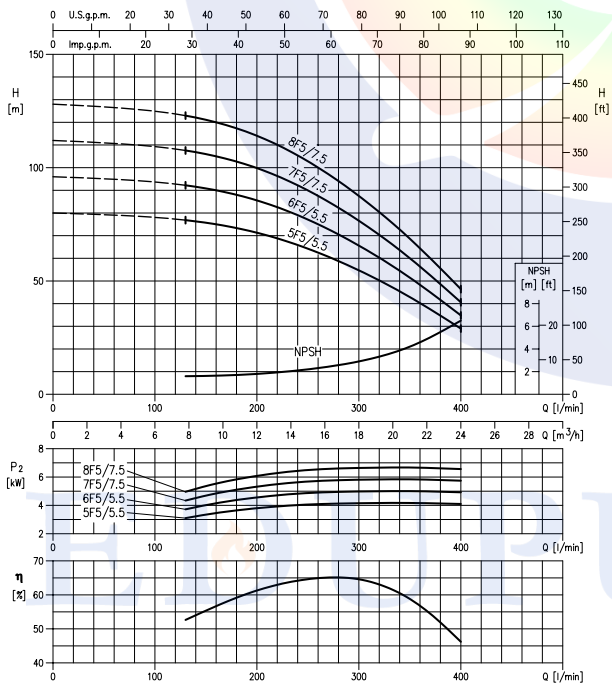

Rotation speed $\approx 2850 \text{ min}^{-1}$
Test standard: ISO 9906-Annex A

EVM 18

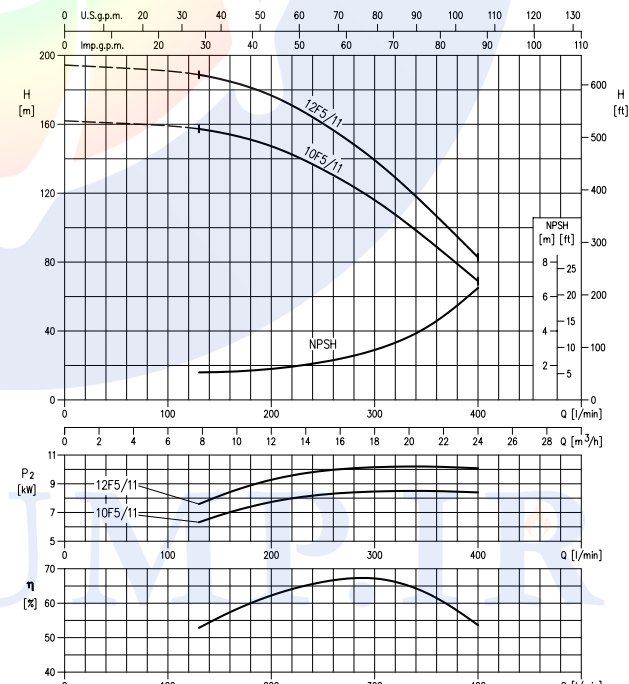

Rotation speed $\approx 2850 \text{ min}^{-1}$
Test standard: ISO 9906-Annex A

EVM 18,32 | Vertical Multistage Pumps in AISI 304, 316

EVM 18

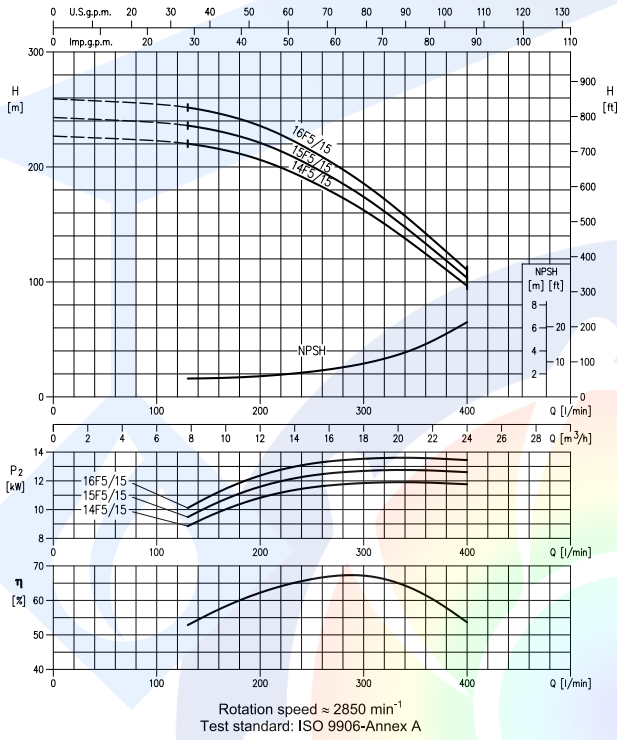

EVM 32

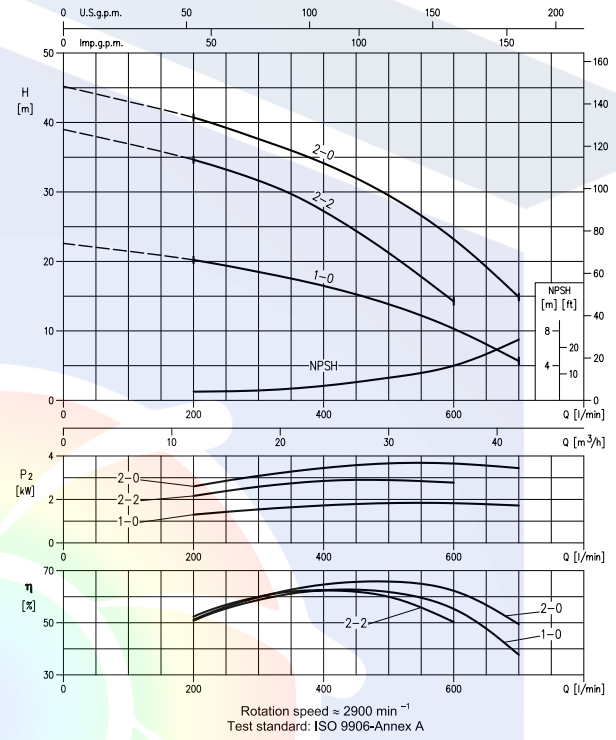

EVM 32

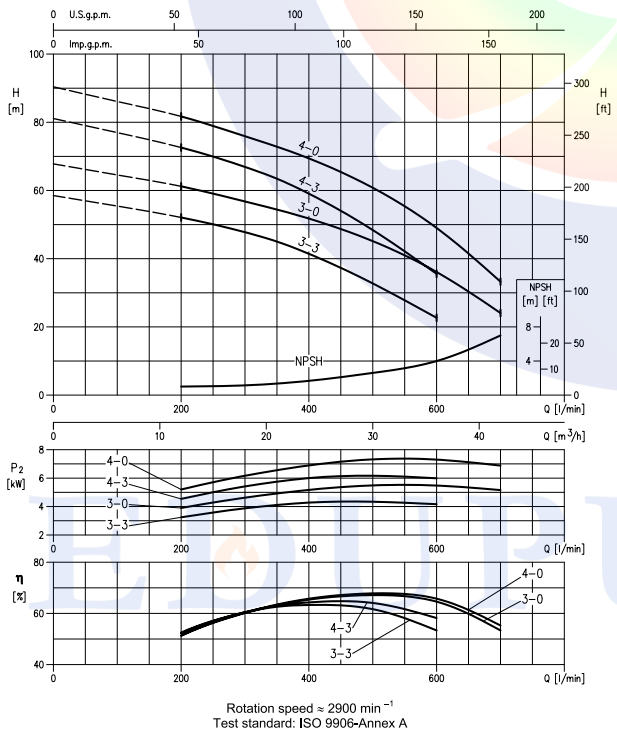

EVM 32

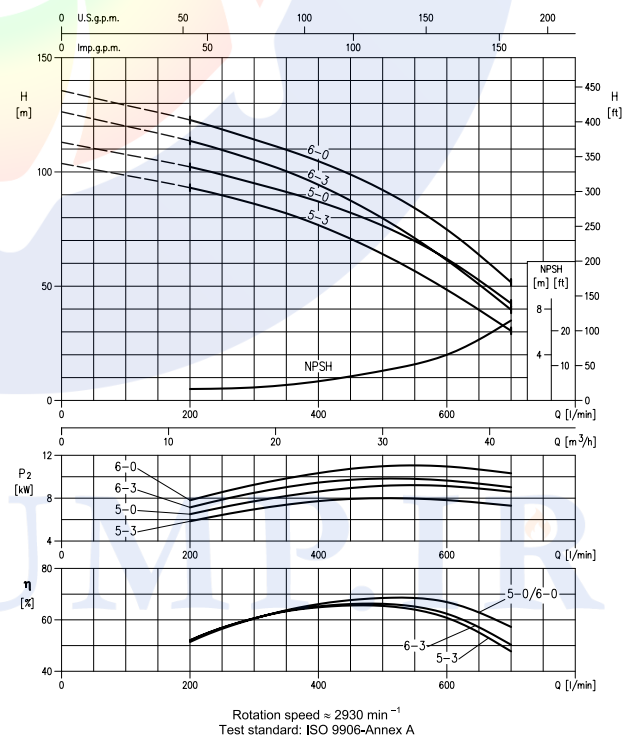

EVM 3-18

Vertical Multistage Pumps in AISI 304 , 316

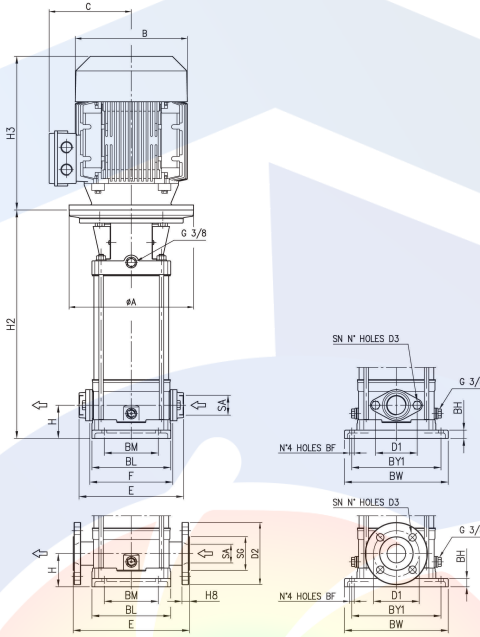

DIMENSIONAL TABLE

جدول ابعادی

Pump Type EVM	Pmax. [MPa]	Motor Size	Dimensions [mm]																								Weight (kg)			
			H	H2	1~	H3	3~	F	E	1~	B	3~	1~	3~	BM	BL	BY1	BW	SA	SG	D1	D2	H8	SN	D3	BF	BH	A	Pump	Pump + motor
EVM 3 2N5/0.37	1.6	71	50	241	215	215	160	206	142	142	129	112	100	149	180	210	210	G 1"	-	75	-	-	2	M10	Ø12	20	Ø105	11.3	17.0	17.0
EVM 3 3N5/0.37	1.6	71	50	262	215	215	160	206	142	142	129	112	100	149	180	210	210	G 1"	-	75	-	-	2	M10	Ø12	20	Ø105	11.8	17.5	17.5
EVM 3 4N5/0.55	1.6	71	50	283	215	215	160	206	142	142	129	112	100	149	180	210	210	G 1"	-	75	-	-	2	M10	Ø12	20	Ø105	12.3	19.3	18.6
EVM 3 5N5/0.55	1.6	71	50	304	215	215	160	206	142	142	129	112	100	149	180	210	210	G 1"	-	75	-	-	2	M10	Ø12	20	Ø105	12.8	19.8	19.1
EVM 3 6N5/0.75	1.6	80	50	335	232	232	160	206	160	160	150	129	100	149	180	210	210	G 1"	-	75	-	-	2	M10	Ø12	20	Ø120	13.7	25.1	22.1
EVM 3 7N5/0.75	1.6	80	50	356	232	232	160	206	160	160	150	129	100	149	180	210	210	G 1"	-	75	-	-	2	M10	Ø12	20	Ø120	13.9	25.3	22.3
EVM 3 9N5/1.1	1.6	80	50	398	232	232	160	206	160	160	150	129	100	149	180	210	210	G 1"	-	75	-	-	2	M10	Ø12	20	Ø120	14.8	26.6	24.3
EVM 3 11N5/1.1	1.6	80	50	440	232	232	160	206	160	160	150	129	100	149	180	210	210	G 1"	-	75	-	-	2	M10	Ø12	20	Ø120	16.2	28.0	25.7
EVM 3 13N5/1.5	1.6	90S	50	492	278	267	160	206	172	180	140	138	100	149	180	210	210	G 1"	-	75	-	-	2	M10	Ø12	20	Ø140	17.7	35.5	30.4
EVM 3 15N5/1.5	1.6	90S	50	534	278	267	160	206	172	180	140	138	100	149	180	210	210	G 1"	-	75	-	-	2	M10	Ø12	20	Ø140	19.2	37.0	31.9
EVM 3 18F5/2.2	2.5	90L	75	632	278	267	-	250	172	180	140	138	100	149	180	210	Ø25	Ø66	Ø85	Ø115	16	4	Ø14	Ø12	20	Ø140	24.8	44.3	40.8	
EVM 3 22F5/2.2	2.5	90L	75	717	278	267	-	250	172	180	140	138	100	149	180	210	Ø25	Ø66	Ø85	Ø115	16	4	Ø14	Ø12	20	Ø140	27.2	46.7	43.2	
EVM 3 26F5/3.0	2.5	100	75	811	-	306	-	250	-	196	-	145	100	149	180	210	Ø25	Ø66	Ø85	Ø115	16	4	Ø14	Ø12	20	Ø160	30.8	-	50.1	
EVM 5 2N5/0.37	1.6	71	50	255	215	215	160	206	142	142	129	112	100	149	180	210	G 1 1/4	-	75	-	-	2	M10	Ø12	20	Ø105	11.5	17.2	17.2	
EVM 5 3N5/0.55	1.6	71	50	283	215	215	160	206	142	142	129	112	100	149	180	210	G 1 1/4	-	75	-	-	2	M10	Ø12	20	Ø105	12.0	19.0	18.3	
EVM 5 4N5/0.75	1.6	80	50	321	232	232	160	206	160	160	150	129	100	149	180	210	G 1 1/4	-	75	-	-	2	M10	Ø12	20	Ø120	12.9	24.3	21.3	
EVM 5 5N5/1.1	1.6	80	50	349	232	232	160	206	160	160	150	129	100	149	180	210	G 1 1/4	-	75	-	-	2	M10	Ø12	20	Ø120	13.5	25.3	23.0	
EVM 5 6N5/1.1	1.6	80	50	377	232	232	160	206	160	160	150	129	100	149	180	210	G 1 1/4	-	75	-	-	2	M10	Ø12	20	Ø120	14.1	25.9	23.6	
EVM 5 7N5/1.5	1.6	90S	50	415	278	267	160	206	172	180	140	138	100	149	180	210	G 1 1/4	-	75	-	-	2	M10	Ø12	20	Ø140	14.9	32.7	27.6	
EVM 5 8N5/1.5	1.6	90S	50	443	278	267	160	206	172	180	140	138	100	149	180	210	G 1 1/4	-	75	-	-	2	M10	Ø12	20	Ø140	15.5	33.3	28.2	
EVM 5 10N5/2.2	1.6	90L	50	509	278	267	160	206	172	180	140	138	100	149	180	210	G 1 1/4	-	75	-	-	2	M10	Ø12	20	Ø140	17.9	37.4	33.9	
EVM 5 11N5/2.2	1.6	90L	50	537	278	267	160	206	172	180	140	138	100	149	180	210	G 1 1/4	-	75	-	-	2	M10	Ø12	20	Ø140	19.0	38.5	35.0	
EVM 5 12N5/2.2	1.6	90L	50	565	278	267	160	206	172	180	140	138	100	149	180	210	G 1 1/4	-	75	-	-	2	M10	Ø12	20	Ø140	19.7	39.2	35.7	
EVM 5 14N5/3.0	1.6	100	50	631	-	306	160	206	-	196	-	145	100	149	180	210	G 1 1/4	-	75	-	-	2	M10	Ø12	20	Ø160	22.0	-	41.3	
EVM 5 16N5/3.0	1.6	100	50	688	-	306	160	206	-	196	-	145	100	149	180	210	G 1 1/4	-	75	-	-	2	M10	Ø12	20	Ø160	23.3	-	42.6	
EVM 5 18F5/4.0	2.5	112	75	769	-	306	-	250	-	196	-	145	100	149	180	210	Ø32	Ø76	Ø100	Ø140	20	4	Ø14	Ø12	20	Ø160	28.7	-	56.1	
EVM 5 19F5/4.0	2.5	112	75	797	-	306	-	250	-	196	-	145	100	149	180	210	Ø32	Ø76	Ø100	Ø140	20	4	Ø14	Ø12	20	Ø160	29.4	-	56.8	
EVM 5 21F5/4.0	2.5	112	75	881	-	306	-	250	-	196	-	145	100	149	180	210	Ø32	Ø76	Ø100	Ø140	20	4	Ø14	Ø12	20	Ø160	31.2	-	58.6	
EVM 5 24F5/5.5	2.5	132S	75	948	-	370	-	250	-	270	-	198	100	149	180	210	Ø32	Ø76	Ø100	Ø140	20	4	Ø14	Ø12	20	Ø300	35.4	-	75.4	
EVM 10 2N5/0.75	1.6	80	80	333	232	232	200	252	160	160	150	129	130	190	215	250	G 1 1/2	-	100	-	-	2	M12	Ø12	20	Ø120	18.0	29.4	26.4	
EVM 10 3N5/1.1	1.6	80	80	363	232	232	200	252	160	160	150	129	130	190	215	250	G 1 1/2	-	100	-	-	2	M12	Ø12	20	Ø120	19.5	31.3	29.0	
EVM 10 4N5/1.5	1.6	90S	80	403	278	267	200	252	172	180	140	138	130	190	215	250	G 1 1/2	-	100	-	-	2	M12	Ø12	20	Ø140	21.9	39.7	34.6	
EVM 10 5N5/2.2	1.6	90L	80	443	278	267	200	252	172	180	140	138	130	190	215	250	G 1 1/2	-	100	-	-	2	M12	Ø12	20	Ø140	22.5	42.0	38.5	
EVM 10 6N5/2.2	1.6	90L	80	473	278	267	200	252	172	180	140	138	130	190	215	250	G 1 1/2	-	100	-	-	2	M12	Ø12	20	Ø140	24.0	43.5	40.0	
EVM 10 8N5/3.0	1.6	100	80	543	-	306	200	252	-	196	-	145	130	190	215	250	G 1 1/2	-	100	-	-	2	M12	Ø12	20	Ø160	30.6	-	49.9	
EVM 10 10N5/4.0	1.6	112	80	603	-	306	200	252	-	196	-	145	130	190	215	250	G 1 1/2	-	100	-	-	2	M12	Ø12	20	Ø160	31.5	-	58.9	
EVM 10 11N5/4.0	1.6	112	80	633	-	306	200	252	-	196	-	145	130	190	215	250	G 1 1/2	-	100	-	-	2	M12	Ø12	20	Ø160	34.0	-	61.4	
EVM 10 12N5/5.5	1.6	132S	80	674	-	370	200	252	-	270	-	198	130	190	215	250	G 1 1/2	-	100	-	-	2	M12	Ø12	20	Ø300	39.3	-	79.3	
EVM 10 14N5/5.5	1.6	132S	80	734	-	370	200	252	-	270	-	198	130	190	215	250	G 1 1/2	-	100	-	-	2	M12	Ø12	20	Ø300	41.8	-	81.8	
EVM 10 15F5/5.5	2.5	132S	80	764	-	370	-	280	-	270	-	198	130	190	215	250	Ø40	Ø88	Ø110	Ø150	20	4	Ø18	Ø12	20	Ø300	45.8	-	85.8	
EVM 10 16F5/7.5	2.5	132S	80	794	-	370	-	280	-	270	-	198	130	190	215	250	Ø40	Ø88	Ø110	Ø150	20	4	Ø18	Ø12	20	Ø300	47.8	-	92.8	
EVM 10 18F5/7.5	2.5	132S	80	854	-	370	-	280	-	270	-	198	130	190	215	250	Ø40	Ø88	Ø110	Ø150	20	4	Ø18	Ø12	20	Ø300	49.8	-	94.8	
EVM 10 20F5/7.5	2.5	132S	80	915	-	370	-	280	-	270	-	198	130	190	215	250	Ø40	Ø88	Ø110	Ø150	20	4	Ø18	Ø12	20	Ø300	49.8	-	94.8	
EVM 10 22F5/11	2.5	160M	80	1005	-	503	-	280	-	335	-	246	130	190	215	250	Ø40	Ø88	Ø110	Ø150	20	4	Ø18	Ø12	20	Ø350	55.5	-	136.5	
EVM 18 2F5/2.2	1.6	90L	90	373	278	267	-	300	172	180	140	138	130	190	215	250	Ø50	Ø102	Ø125	Ø165	20	4	Ø18	Ø12	20	Ø140	27.4	46.9	43.4	
EVM 18 3F5/3.0	1.6	100	90	420	-	306	-	300	-	196	-	145	130	190	215	250	Ø50	Ø102	Ø125	Ø165	20	4	Ø18	Ø12	20	Ø160	28.9	28.9	48.2	
EVM 18 4F5/4.0	1.6	112	90	473	-	306	-	300	-	196	-	145	130	190	215	250	Ø50	Ø102	Ø125	Ø165	20	4	Ø18	Ø12	20	Ø160	31.4	-	58.8	
EVM 18 5F5/5.5	1.6	132S	90	524	-	370	-	300	-	270	-	198	130	190	215	250	Ø50	Ø102	Ø125	Ø165										

شرکت پیشگامان صنعت و ایمنی پرگاس



گروه تخصصی اطفاء حریق

 Edufire.ir

 [Edufire.ir](https://www.instagram.com/Edufire.ir)



گروه تخصصی سیستم‌های پمپاژ

 Edupump.ir

 [Edupump.ir](https://www.instagram.com/Edupump.ir)



گروه تخصصی اعلان حریق

 Edualarm.ir

 [Edualarm.ir](https://www.instagram.com/Edualarm.ir)



گروه تخصصی تاسیسات مکانیکی

 Eduhvac.ir

 [Eduhvac.ir](https://www.instagram.com/Eduhvac.ir)

